

Instructions for the labeling, packaging and delivery of goods

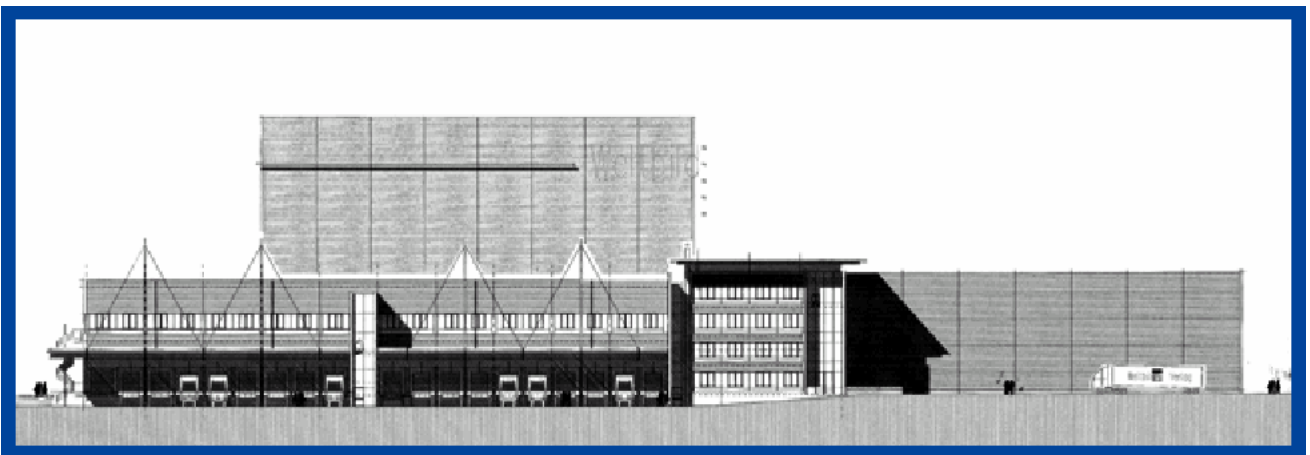

Imprint:
© 2002 Verlagsgruppe Weltbild GmbH
Version No. 5 / 070124
Design and copy: Logistics Manager
Printed in Germany

Content

- 1. Addresses and delivery address.....Page 4**
- 2. Labeling of articles and individual article packaging.....Page 5**
- 3. Packaging in standard supplier cartons (SSC).....Page 7**
- 4. Delivery of standard cartonsPage 9**
- 5. Load carriersPage 10**
- 6. Special articlesPage 17**
- 7. Accompanying papers, invoicesPage 18**
- 8. Delivery datePage 21**
- 9. Important information for deliveriesPage 22**
- AppendicesPage 24**

1. Addresses and addresses for delivery

1.1 Delivery address for consignment of goods

Delivery in accordance with the WELTBILD order.

1.2 Delivery address for samples dispatch and correspondence with Verlagsgruppe Weltbild GmbH

VERLAGSGRUPPE WELTBILD GMBH
Steinerne Furt 67
Contact and room no. as per order
86167 Augsburg

sample consignments are usually free domicile.

For each consignment / letter, the purchasing dept, source reference of the purchasing dept. and the order number etc. must be given.

1.3 Our department responsible for all queries relating to goods labeling, packaging or goods and delivery:

a) Dept. Name: Receipt of Goods
b) Address: VERLAGSGRUPPE WELTBILD GMBH
Pfaffenhofener Str. 15
86167 Augsburg
b) Tel. No.: 0821/70 04 97 25
c) Fax No.: 0821/70 04 97 29

You save time and money
if you contact us FIRST if you are in doubt.

Our goods receipt department is pleased to be at your
disposal for additional information.

Our instructions on labeling, packaging and delivery are to be found on the internet at
www.weltbild.com/lieferanweisung.

2. Labeling of articles and individual article packaging

2.1 Individually packaged articles

2.2.1 Single unit packaging must always consist of environment-friendly, recyclable material and is to be marked with the Green Dot.

Polythene bags, stretch foils and cling foils must be polythene foils.

Packaging which contains CFCs or PVC or similar and packaging which does not conform to our regulations will be disposed of at your expense.

2.1.2 Once chosen, the same packaging must continue to be used. Modifications permissible only with our prior consent!

2.1.3 The content of the single unit packaging must conform to the sales unit quoted in our order.

2.2 Labeling for Single Unit Packaging

2.2.1 Each article (a single unit) must be identified by means of our article number and/or a barcode (EAN 13, UPC-A), books additionally with the ISBN.

Example:

sound medium, software, games: EAN 13 – SC 0, UPC-A
books: EAN 13 – SC 0 and ISBN

Barcode as norm SC 0 = 0.82 (30.5 x 21.48 mm) +/- 0.042 mm

All WELTBILD article numbers have 9 digits.

WELTBILD article no.: 6 digits

WELTBILD volume no.: 3 digits

A blank space should be left between the two numbers.

2.2.2 The WELTBILD article number inclusive the volume number can be found in our order.

2.2.3 Articles in paper bags, individual cartons or fabric bags must be identified with the WELTBILD article and volume number, WELTBILD article designation or abbreviated titles, the EAN 13-SC 0 or UPC-A barcode on the back of the individual packaging.

The labels must not be smaller than the minimum size 4 cm long x 2.5 cm high.

it is not permissible for a supplier number to be quoted on the article/label or on any part of the packaging.

For books, labeling must be placed on side 4 of the book cover (back) and, for all other articles, on the back or the side with the most space.

The identification code must be the same for each item per article.

The identification code must always be visible from the outside, without having to open the packaging.

The barcode must be able to be read by commonly used manual readers, hand scanners and stationary automatic scanners.

3. Packaging in standard supplier cartons (SSC)

3.1 In order to avoid additional packaging, protective cartons should not be used when

- the article can be delivered without a protective carton
- the article and transport insurance is already provided.

All consignments in a protective carton must be made exclusively in standard cartons (protective cartons) with the following sizes:

External dimensions (in mm)			
SSC NO.	length	width	height
SSC 1	400	300	200
SSC 2	600	400	200
SSC 3	600	400	300

Max. carton weight: 15 kg

Cartons pre-printed with "RESY" are to be used.

3.2 SSCs have the function of protective cartons, i.e. they must contain only identical articles (same article cartons).

3.3 The content / SSC is stipulated at the time of the first order (items / SSC).

All SSCs / articles in one consignment must have the same content (items / SSC).

For subsequent deliveries the stipulated number of items / SSC must be observed.

3.4 Depending on the volume of the goods, other carton sizes can be used in individual cases. In such cases the dimensions of these must not exceed those of the largest SSC in length x width x height.

3.5 The supplier shall bear the responsibility for packaging which is suitable for the article and for transport . The safety of the packaging is absolutely and exclusively the full responsibility of the supplier and should, specifically in the case of fragile goods, be tested by means of drop tests in accordance with the specifications of the Deutsche Post and with DIN 55468, part 1.

3.6 The SSCs shall always bear a standard label (see Appendix 2 and copy form in Appendix 4) on the front (please see example in 3.10.).

3.7 The carton label (on the front) is to be completed in full - exclusively with WELTBILD data.

3.8 The weight of a SSC with contents must not exceed 15 kg.

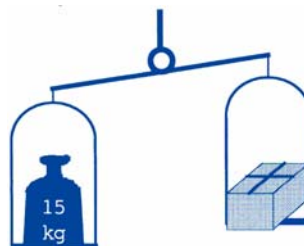

3.9 No filler material is to be used. Filler materials may be used only with prior written consent of our goods received department.

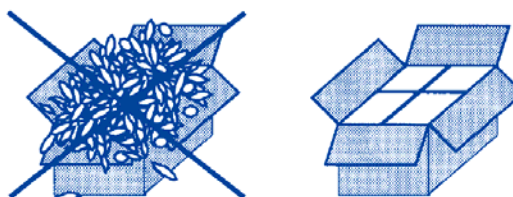

3.10 SSCs must not be overpacked, causing the sides, top or bottom to bulge out.

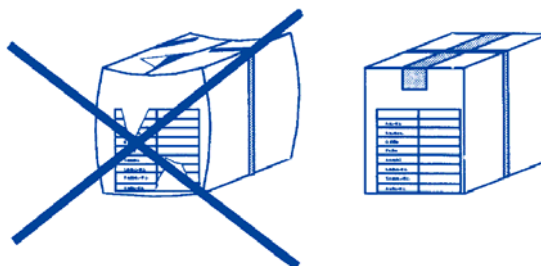

3.11 The SSCs must not be packed using special plastic band.

4. Delivery of Standard Cartons

- 4.1 Each consignment must be accompanied by a delivery note. The delivery note must be well visible from the outside, regardless of whether the cartons are delivered on a pallet or not.
- 4.2 The delivery note must be attached to the long side of the carton printed clearly with the words for example: "HERE DELIVERY NOTE" or "DELIVERY NOTE".

The delivery note must be clearly recognizable as such and must be suitably protected e. g. by using a document envelope in plastic or reinforced paper.

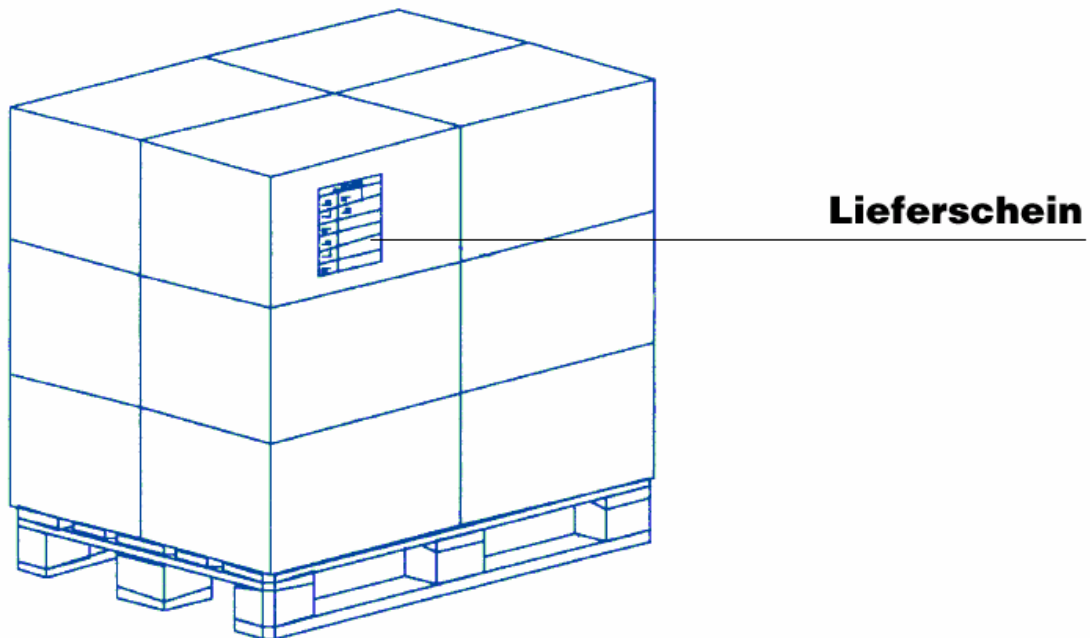

5. Load Carriers

5.1 Load Carriers

The delivery of article items on pallets is permissible solely on undamaged EURO pallets.

Note:

Coarse screen boxes and detachable pallet frames must not be used.

Pallet dimensions incl. load

Length = 1,200 mm

Width = 800 mm

Height = 1,400 mm

Permissible total load: max. 1,000 kg

Minimum pallet height (incl. pallet): 0.6 m

If the last pallet with remaining articles would be less than 0.6 m, the two last pallets are to be packed to equal height.

Pallets are to be placed lengthways on the truck surface for delivery.

The last two pallets can be placed sideways to make maximum use of loading room.

5.2 Pallet overload

Overloading the pallets is not permissible.

5.3 Article / Pallets

- Pallets are always to be delivered with articles of the same type (1 article / pallet). Pallets with several different articles will not be accepted. The costs of returning the goods and/or loading pallets with the same articles will be charged to the supplier.

5.4 Euro pallets

- Pallets must conform to the EURO norm for pallets.
- Damaged pallets will not be accepted.
- All costs incurred as a result of damaged pallets or pallets which do not conform to the EURO pallet standard will be charged to the supplier.
- Overloaded pallets will not be accepted. Costs of re-palleting will be charged to the supplier.

The following information is based on the "UIC Code 435-2 Standard of quality for a European flat wood pallet, with four entries, and measuring 800 x 1200 mm" issued by the International Union of Railways, 7th edition, 01.07.94 and the pallet organisation EPAL (European Pallet Association)

➤ Requirements on pallet quality (source: www.epal-pallets.org)

- Bottom or top deck lead boards must not be splintered.
- Boards must not be broken either transversely or diagonally.
- No boards or blocks must be missing. The blocks must not be twisted round.
- The load capacity of the pallet must not be impaired due to rotting boards or blocks.
- The pallet must not be dirty so that no products carried on it are contaminated.
- There must be no splits in blocks.
- There must be no inadmissible components on the pallet (e.g. boards that are too thin, blocks that are too narrow).



- Repaired pallets must be identified by a repair nail on a centre block on the long side.



- Quality-approved pallets also have the EPAL control clamp, which is located immediately under the D of the symbol on the centre block of the pallet.



- Pallets must have the three symbols on the long side.

Left: Symbol of a European railway company, e.g. DB for German Railways

Centre: Quality symbol of the European Pallet Association (EPAL) and the manufacturer's code.
The manufacturer's code 000-0-00 denotes in the

- first group (numbers/letters) the licensed manufacturer
- second group the last number of the year of manufacture and the month of manufacture

Right: Symbol of the European pallet pool of the railways, the EUR symbol

➤ **Components of the European pallet with four entries:**

- 78 nails
- 54 convex ring nails
- 3 blocks 145 x 145 x 78 mm
- 6 blocks 145 x 100 x 78 mm
- 2 deck boards 1200 x 100 x 22 mm
- 3 deck boards 1200 x 145 x 22 mm
- 3 stringer boards 800 x 145 x 22 mm
- 1 bottom board 1200 x 145 x 22 mm
- 2 bottom boards 1200 x 100 x 22 mm

- **Dimensions and permitted deviations of pallet components**
(source: www.epal-pallets.org):

Part	Component ¹⁾	Number of components	Dimensions at 22% moisture content		
			Length	Width	Depth
1	Bottom deck lead board	2	1 200 + 3/-0	100 ± 3	22 + 2/0
2	Top deck lead board	2	1 200 + 3/-0	145 +5/-3	22 + 2/0
3	Central bottom deck board	1	1 200 + 3/-0	145 +5/-3	22 + 2/0
4	Stringer board	3	800 + 3/-0	145 + 5/-3	22 +3/-0
5	Central top deck board	1	1 200 + 3/-0	145 + 5/-3	22 + 2/0
6	Intermediate top deck board	2	1 200 + 3/-0	100 ± 3	22 + 2/0
7	Outer skid block	6	145 +5/-3	100 ± 3	78 + 1/0
8	Centre skid block	3	145 +5/-3	145 + 5/-3	78 + 1/0

¹⁾ see figure below

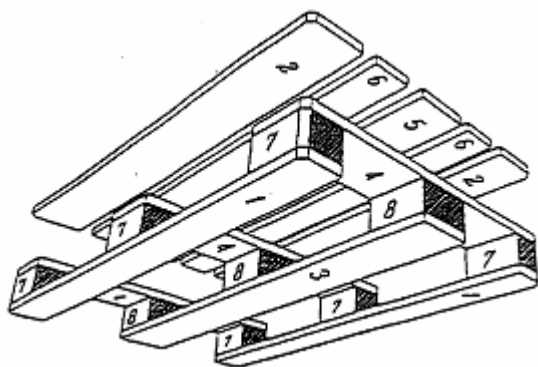

Further details about nail patterns for the top and underneath, parts lists for approved fastening elements and section drawings can be found in the "UIC Code 435-2 Standard of quality for a European flat wood pallet, with four entries, and measuring 800 x 1200 mm" issued by the International Union of Railways, 7th edition, 01.07.94.

5.5 Pallet identification

Each pallet must be correctly identified.

Form: see Appendix 2 and form for copying in Appendix 3

Pallet labeling

The pallet labeling must be attached to both narrow sides of the pallet in the top third section of the pallet safeguard and must be easily identifiable.

Pallet labeling must be completed in full and exclusively with WELTBILD data.

The barcode must be able to be read by commonly used manual readers, hand scanners and stationary automatic scanners.

Any pallet not labeled will be

- returned,
- or the contents will be examined in full and we will provide a label at the expense of the supplier.

5.6 Delivery Note

All consignments without exception must be accompanied by a delivery note.

The delivery note must be attached in the top third section of the pallet safeguard on one of the narrow pallet sides with a clear notice e.g. "HERE DELIVERY NOTE" or "DELIVERY NOTE".

The delivery note is to be adequately protected against damage e.g. by means of a document envelope made of plastic or reinforced paper.

5.7 Securing the load

As far as possible the goods are to be secured by means of stretch foils.

The load must be secured with foil in a way enabling the pallet to be transported on an automatic conveying system. The material used for securing the load must in all cases be environment-compatible and recyclable. The foil must not be secured to the foot of the pallet.

Stretch foils must be made of polyethylene.

Packaging containing CFCS or PVC or similar which do not conform to our regulations, will be disposed of at your expense.

For reasons of stability, intermediate layers of cardboard or paper (in a suitably stable quality) must be used as well as stretch foil.

Steel bands and pallet top covers made of wood must not be used (for exceptions, see Section 5.9).

5.8 Number of items per pallet

When the first order is placed, the quantity per pallet is stipulated by the supplier. The pallet dimensions and weight as stipulated in Section 5.1 must be taken into account.

All pallets with the same article should be loaded with the same number of articles per pallet. The only exception is the pallet with the remaining quantity. The remaining quantity should be smaller than the quantity per pallet stipulated by the supplier.

For subsequent deliveries, the quantity per pallet stipulated in the first delivery must be observed.

5.9 Brief summary of "Ideal Pallet Delivery"

Pallets should always be delivered as described in Alternative A below:

Alternative A

- undamaged Euro pallets
- no edge protection
- a sheet of cardboard must be laid between pallet and first layer
- paper after each intermediate layer
- pallet height of 1.40 m (incl. pallet) is to be used in full if possible (no mixed pallets)
- layers to be stacked in alternating directions
- pallet covering:
 - foil cover stretched
- no side projection is permitted
- pallet label must not be enclosed between stretch foil layers
- for safer transportation, foil can be stretched over pallet feet
- foil must not be knotted to pallet feet

If the procedure as described under Alternative A is not possible for good reasons (e.g. necessary pressure on books), the following procedure will be accepted in exceptional cases:

Alternative B

- undamaged Euro pallets
- no edge protection
- a sheet of cardboard must be laid between pallet and first layer
- paper after each intermediate layer
- pallet height of 1.40 m (incl. pallet) is to be used in full if possible (no mixed pallets)
- layers to be stacked in alternating directions
- pallet covering:
 - foil cover stretched
 - NON-stretched cardboard sheet (over foil cover)
 - wooden lid on cardboard sheet
- pallet foot spaces must not be covered by stretch foil
- stretch foil must not be knotted to pallet feet
- no side projection is permitted
- pallet label must not be enclosed between foil layers
- plastic tapes over stretched foil

5.10 Change of Pallets

Euro pallets are changed by WELTBILD previously at delivery. If pallets are not changed due to an order of the delivering company WELTBILD is permitted to charge storage costs.

6. Special Articles

Special articles are articles which because of their dimensions, weight or other properties are not suitable for transport and/or storage on EURO pallets – according to pallet requirements (Section 5).

Articles which are deemed to be special articles by Verlagsgruppe Weltbild GmbH will be specifically indicated in the order. For these articles there may be individual points in these instructions for labeling, packaging and delivery which cannot be applied.

In respect of possible deviations and substitute measures required, the supplier shall reach agreement on the details with Verlagsgruppe Weltbild GmbH (merchandise management dept.) prior to shipment and in writing.

In the event that no consent has been obtained or no agreement on article labeling and packaging reached with Verlagsgruppe Weltbild GmbH, the general requirements of these instructions on labeling, packaging and delivery remain in force without restrictions.

In the event of deviation from the special agreements reached, any costs arising therefrom and incurred by Verlagsgruppe Weltbild GmbH will be charged in full to the supplier.

Mixed pallets are only permissible if individual protective cartons containing several articles have to be put together for technical reasons relating to transport.

7. Accompanying Documents, Invoices

7.1 Consignment note

A consignment note from the forwarding agent must be submitted for each consignment delivered.

Information on the consignment note must always include the following:

- **The WELTBILD order No.**
- The delivery note no.
- Terms of delivery (free house, unpaid)
- The quantity of units (number of pallets, number of individual cartons in the case of non pallet delivery)
- Weight of the consignment

7.2 Delivery Note

At least one delivery note is to be provided with each consignment delivered. On the delivery note, the individually listed article items are to be collated according to WELTBILD order numbers.

The delivery note stays with the goods and must be clearly visible (please see Section 4.1-4.2, 5.6).

The essential information required on the delivery note:

- WELTBILD order no.
- WELTBILD article no.
- WELTBILD article designation (title)
- Quantity of items per article number. and volume number
- Supplier information
 - name, address
 - name of contact person with telephone and fax number.

If the supplier is not the sender, then the following information must also be supplied for the sender:

- name, address
- name of contact person with telephone and fax number.

7.3 Invoice

The goods invoice is sent separately to the goods delivery. It must be sent to the person, department and address given in the order.

The invoice contains the articles of one WELTBILD order number. To debit more order numbers, you have to generate a certain invoice for each order number.

It is essential that the goods invoice contains the following information:

- Invoice address as given in order, or otherwise

VERLAGSGRUPPE WELTBILD GMBH
Abt. Finanzbuchhaltung
Steinerne Furt 65 – 70

D - 86167 Augsburg
Germany

- Invoice number
- Date of invoice
- Amount of invoice, stating the currency.
- Separate details of the value added tax and rate of tax.
- The agreed conditions of payment as given in the order.
- Date of order (date, person ordering, WELTBILD order number, WELTBILD article no., quantity per article no.).
- Sales Tax Identification Number of the supplier and of WELTBILD.

In addition the following details should be given:

- WELTBILD article designation
- Delivery note no.

For part deliveries, all delivery note numbers must be listed.

7.4 General Information

Most of the data required can be found in the WELTBILD order.

The remaining details are known to you from your own consignment information e.g. delivery note number, sender, number of packaged units.

The information required on the forms is absolutely essential to ensure smooth processing. If details are missing or not complete, this leads to considerable extra processing work for WELTBILD. These extra costs incurred will be charged in full to the supplier.

8. Delivery Date

A delivery date with time window will be specified in the WELTBILD order.

This date is reserved for your delivery with the order and timed to fit in with our logistic procedures. Observance of the delivery date guarantees rapid processing and take over of the goods.

It is absolutely necessary that you or your delivering company announce the delivery one working day before the delivery. The announcement has to be written or by telephone at our receipt of goods department. Please advise us the number of pallets, the supplier of the article, the WELTBILD order number and the WELTBILD article number. We will inform you about the delivering date and time. If you don't announce the delivery it might lead to longer waiting times.

You can announce:

- Per Fax: 0049 - (0)821 – 7004 - 9729
- Per E-Mail: wareneingang@weltbild.com
- Per Telephon: 0049 – (0)821 – 7004 - 9725

Should the delivery date not be met, this will effect the whole process for incoming goods and for subsequent logistic procedures.

9. Important information for deliveries

9.1 We ask you to make sure that your deliveries are made in conformity with

- the specifications in the WELTBILD order
- WELTBILD instructions on labeling, packaging and delivery
- the delivery date.

9.2 For any queries you may have, please contact the WELTBILD Department or the relevant WELTBILD contact person, in accordance with details given under Section 1.3 .

9.3 We draw your attention specifically to the fact that :

- These instructions are part of the supply agreement.
- All costs involved in cases of non-observance of these instructions will be charged to the supplier.

Please note:

Our success is your success. Only together in collaboration can we achieve the objective we have set ourselves, namely rational processing of orders.

Please contact us in time, before problems arise.

Best regards

VERLAGSGRUPPE WELTBILD GmbH

**PLEASE DO EVERYTHING
IN YOUR POWER TO ENSURE
THAT DELIVERY RUNS SMOOTHLY!**

**WE ARE LOOKING FORWARD TO
A GOOD WORKING RELATIONSHIP.**

Verlagsgruppe Weltbild  GmbH

Appendix 1

WELTBILD

Article identification label

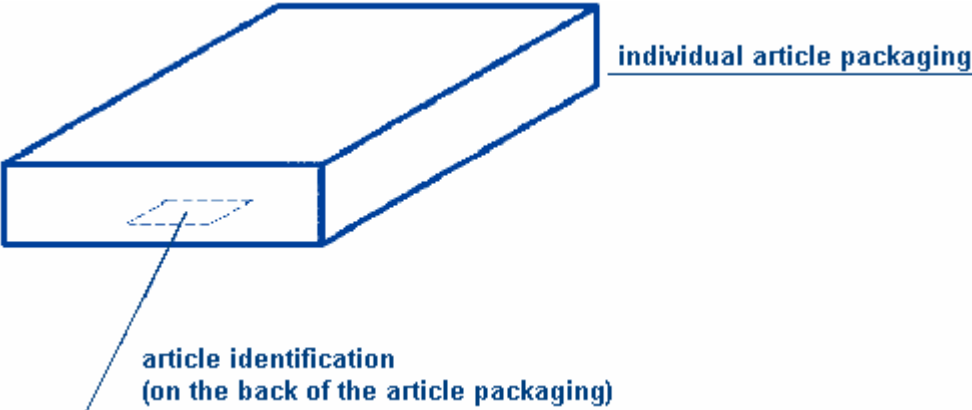

Label dimensions: approx. l x h = 40 x 25 mm

Appendix 2

WELTBILD

Identification label for pallets and cartons

Verlagsgruppe Weltbild GmbH	
Order No.	XXXXXXXXXX 
Art. No and Volume No.	XXXXXX XXX 
Art. Description	
Number of items	
Supplier	

Note:
*Barcode 2/5 interleaved (ITF-Code)

Appendix 3

WELTBILD

Form to be copied for pallet labeling

Verlagsgruppe Weltbild GmbH		
Order No.	<hr/>	
Art. No and Volume No.	<hr/> / <hr/>	
Art. Description		
Number of items		
Supplier		
IDENTIFICATION	PALETTES	

Appendix 4

WELTBILD

Form to be copied for labeling supplier standard cartons

Verlagsgruppe Weltbild GmbH		
Order No.	_____	
Art. No and Volume No.	_____/____	
Art. Description		
Number of items		
Supplier		
IDENTIFICATION	Supplier - Standard - Cartons	